

Installation Note

Agilent Technologies E4407B Spectrum Analyzer External Mixing (Option AYZ) Retrofit Kit



Agilent Technologies



E4407-90031

Part Number E4407-90031 Supersedes: E4407-90015

Printed in USA April 2003

Notice.

The information contained in this document is subject to change without notice.

Agilent Technologies makes no warranty of any kind with regard to this material, including but not limited to, the implied warranties of merchantability and fitness for a particular purpose. Agilent Technologies shall not be liable for errors contained herein or for incidental or consequential damages in connection with the furnishing, performance, or use of this material.

Microsoft® is a U.S. registered trademark of Microsoft Corp.

Introduction

This procedure can be used to retrofit External Mixing (Option AYZ) into an E4407B spectrum analyzer. This kit contains connector labels for analyzers with and without the 100Hz Low Frequency Extension (Option UKB); only one connector label will be used.

Products Affected:	E4407B
Serial Numbers:.....	US39430000/US99999999 MY00000000/MY99999999
Options:	UKB
To Be Performed By:	(X) Agilent Technologies Service Center (X) Personnel Qualified by Agilent (Note: must have necessary test equipment and ESA Adjustment and Performance test software, Option 0BW.) () Customer
Estimated Installation Time:	2.0 Hours
Estimated Verification Time:	3.0 Hours

Installation Kit Parts Lists

Item	Description	Part Number
1	Adapter, SMA (f) to SMA (f) (Qty 2)	1250-1666
2	Cable Assembly, LOIS to Front Panel LO OUT	E4404-20006
3	Cable Assembly, LOIS to Front Panel IF INPUT	E4407-60008
4	O-Ring, 0.237 in. diameter (Qty 2)	0905-0790
5	Washer, Flat 0.255 in. ID (Qty 2)	3050-0420
6	Connector Label, Non-Opt UKB (A1MP21)	E4407-80005
7	Connector Label, Opt UKB (A1MP21)	E4407-80008
8	Option AYZ Installation Note	this note
9	License Key Certificate	5964-5136 ^a
10	Letter	5964-5139 ^a
11	LO Amp/IF Switch assembly	E4404-60030

- a. This part cannot be ordered. The part number is given to identify the item in this kit.

NOTE After the hardware modifications have been made and Option AYZ has been activated, you must adjust the IF INPUT sensitivity of the analyzer. It may also be necessary to adjust the 1st LO OUTPUT Power. The ESA Adjustment Software is required to perform these adjustments, but is not included in this kit. Obtain the software by ordering the Service Documentation and Software Option (Option 0BW) or send the instrument into an Agilent service center for adjustments and verification.

Tools Required

- T-10 TORX screwdriver
- T-15 TORX screwdriver
- Flat-blade screwdriver
- Sharp knife or razor blade
- Synthesized Sweeper
- Power Meter, Dual-Channel
- RF Power Sensor (2 required)
- Microwave Power Sensor
- APC 3.5 (m) Cable Assembly
- Performance Verification and Adjustment Software

The Performance Verification and Adjustment Software may be obtained by ordering the Service Documentation and Software (Option 0BW).

Torque Settings

To avoid potential RFI leakage and prevent connector damage, tighten screws and RF coax cable connectors to the following torque limits:

Item	Torque in Inch-Pounds
SMA Connector	10
3.5-mm, T-10 TORX screws	9
4-mm, T-15 TORX screws	21
Pozidrive Screws	9

Procedure

Verify A8A1 3 GHz RF Assembly Part Number

1. Turn on the analyzer and wait for the initial adjustments to complete.
2. Press **System, More, Show Hdw.** This displays the Show Hardware screen, which lists the part number and serial number of most of the installed board assemblies.
3. Locate the part number of the “50Ω 3 GHz Input” assembly.
4. If the part number of the 50Ω 3 GHz Input assembly is E440360002 or lower, the A8A1 3 GHz RF assembly must be replaced. If the analyzer does not have the High Stability Frequency Reference, Option 1D5, order E4403-60073. If the analyzer does have Option 1D5, order E4403-60074.

WARNING Before you disassemble the instrument, turn the power switch OFF and unplug the instrument. Failure to unplug the instrument can result in personal injury.

CAUTION Electrostatic discharge (ESD) can damage or destroy electronic components. All work on electronic assemblies should be performed at a static-safe workstation. Refer to the documentation that pertains to your instrument for information about static-safe workstations and ordering static-safe accessories.

Dress Cover Removal

1. Referring to [Figure 1](#), disconnect the analyzer from ac power (1).
2. Remove any adapters or cables (2) connected to the front frame.
3. Carefully place the analyzer on the work surface with the front frame (3) facing down.
4. Position the handle (4) as shown.
5. Remove the four screws (5) that hold the rear frame and dress cover in place.
6. Remove the rear frame (6).
7. Pull the dress cover (7) off towards the rear of the analyzer.

Figure 1 Dress Cover and Rear Frame Removal

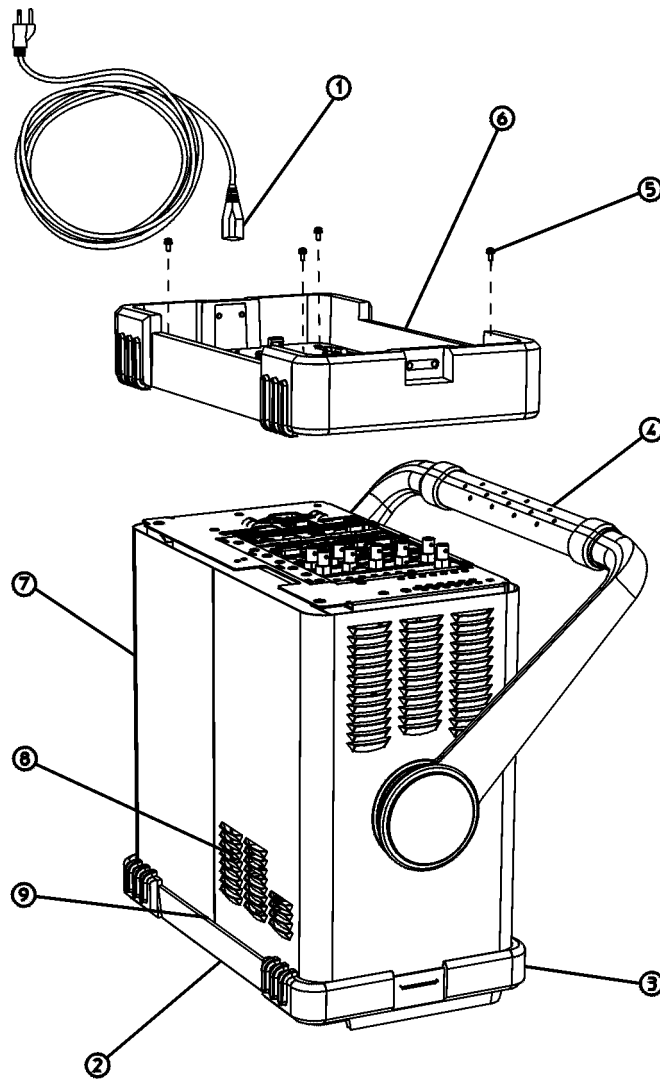

s745b

Chassis Cover Removal

1. Lay the analyzer flat as shown in [Figure 2](#).
2. Remove the screws (3) attaching the chassis cover to the chassis. Note that the number of screws attaching the chassis cover may vary with option mixes.
3. Remove the chassis cover (1) from the chassis.

Figure 2 Chassis Cover Removal

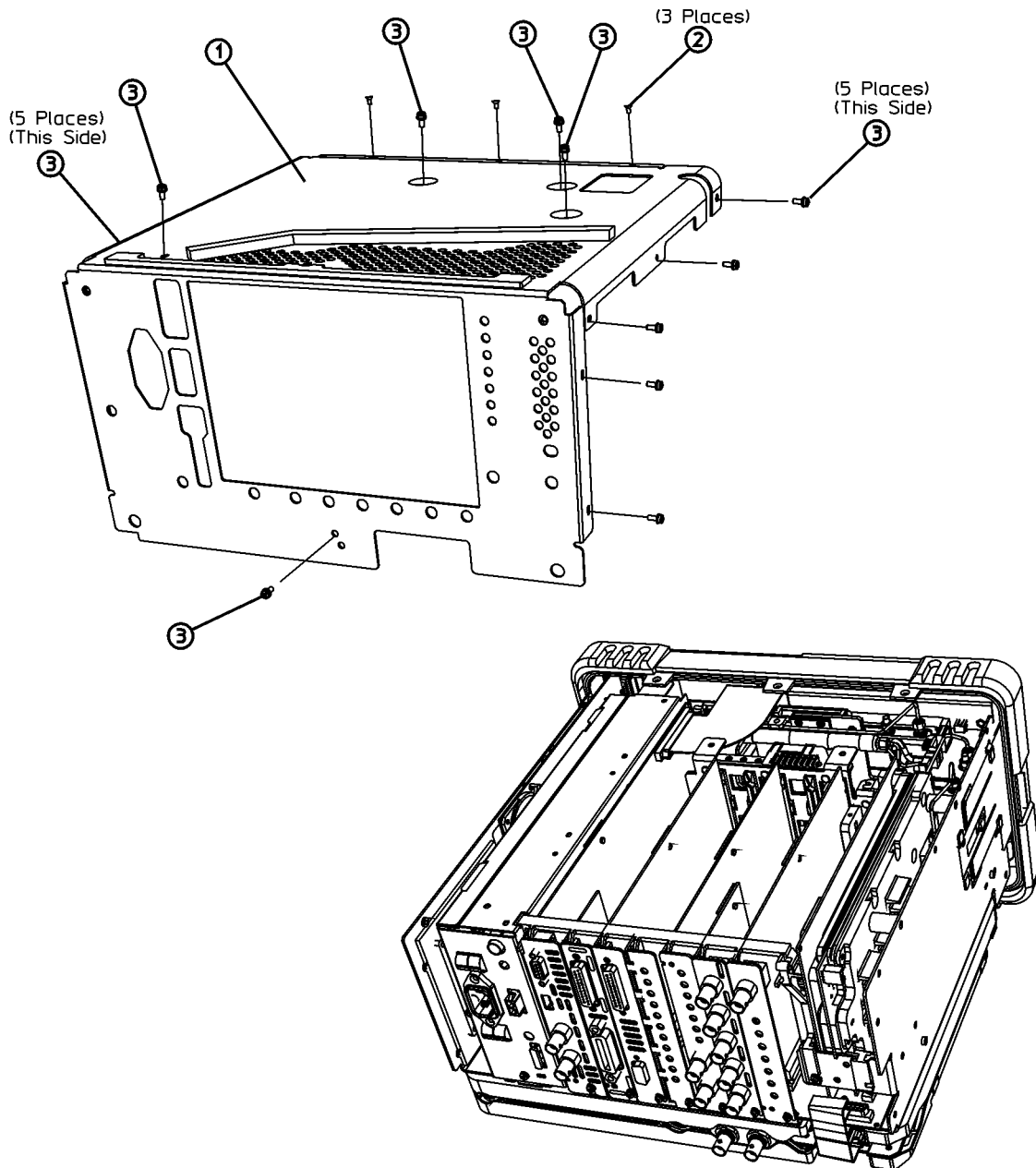

sl746b

A1 Front Frame Assembly

CAUTION Use ESD precautions when performing this replacement procedure.

Extension

The A1 front frame assembly can be extended from the instrument without detaching any connections.

1. Refer to [Figure 3](#). Remove the two screws (1), on the bottom side of the instrument, that secure the front frame to the RF assembly.

Figure 3 A1 Front Frame Assembly Removal

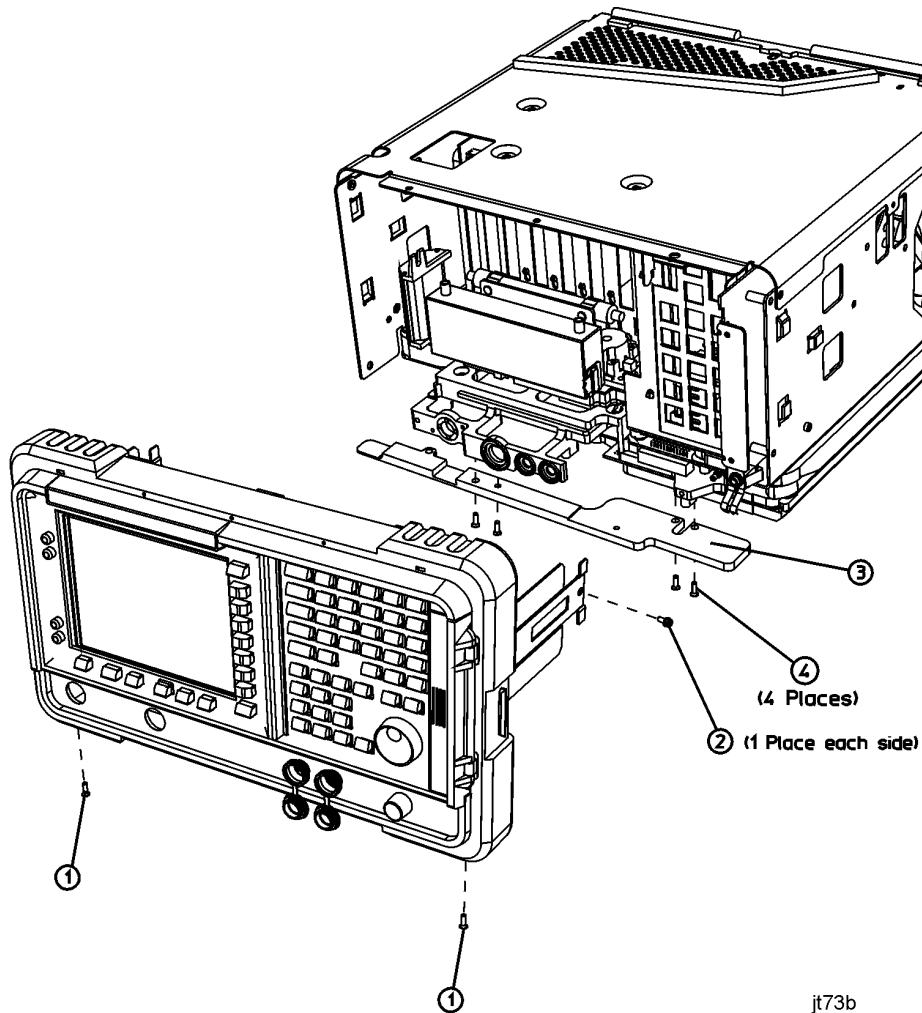

2. Place the instrument with the top side facing up and remove the remaining two screws (2) that secure the front frame subpanel to the chassis.
3. Slide the front frame forward until it catches on the tabs on the sides of the chassis.

Removal

To completely remove the A1 front frame assembly, complete the “Extension” procedure, then continue with the following steps:

1. Refer to [Figure 4](#). Disconnect the ribbon cable (1) from the A1A1 front panel interface board. Analyzers with Option B7B will have a second ribbon cable connecting to A1A1. Disconnect the second ribbon cable if present.

Figure 4 Front Frame Ribbon Cable

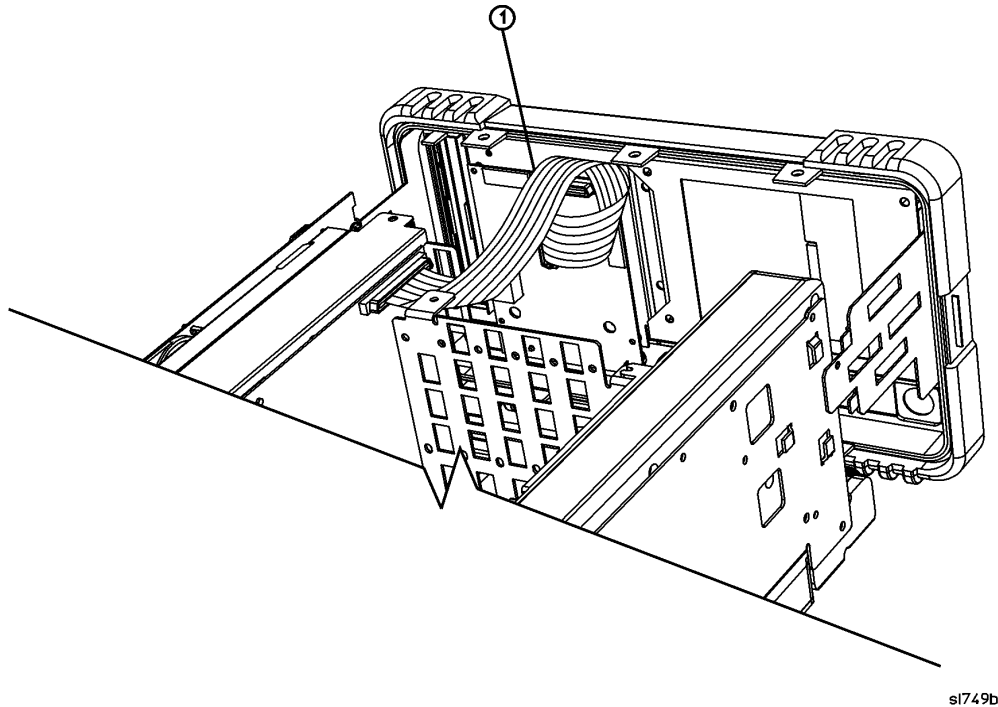

2. Carefully pull the sides of the front frame subpanel away from the chassis and over the tabs on the chassis.
3. Slide the front frame forward to disengage from the chassis assembly.

Install A8A4 LOIS Assembly (provided in this kit)

1. Refer to [Figure 5](#). Locate the A8A4 LO/IF Amplifier/Switch (LOIS) in the microcircuit area.

Figure 5 **Removing A8A4 LOIS Assembly**

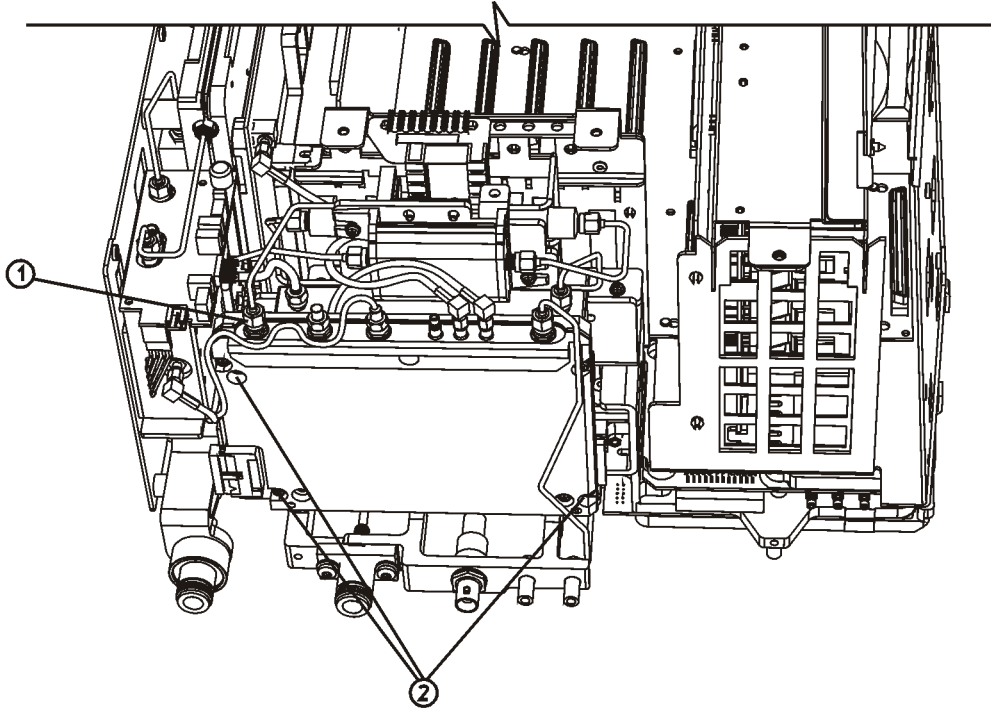

sl775b

2. Disconnect any cables and loads (1) from the LOIS assembly.
 3. Remove the three screws (2) and remove the LOIS assembly.
 4. Install the LOIS assembly supplied in this kit and secure in place with the three screws. Tighten to 9 inch-pounds.
- Caution: Use care not to pinch any cables during reassembly.
5. Reconnect the cables and loads to the correct locations. Tighten the SMA connectors to 10 inch-pounds.
 6. Record the LO Dac values from the label affixed to the front of the A8A4 LOIS assembly for future use during the LO Power adjustment.

Band = 1	Dac Value = _____
Band = 2	Dac Value = _____
Band = 3	Dac Value = _____
Band = 4	Dac Value = _____
TG LO	Dac Value = _____
EXT LO	Dac Value = _____

A1A1 Front Panel Interface Board Removal

1. Refer to [Figure 6](#). Remove the disk drive door (1).
2. Remove the RPG knob (2).
3. Remove the volume knob (3).

TIP You may need to exert considerable force in order to remove the RPG knob. It may be necessary to pry it off using a screwdriver as shown in [Figure 6](#).

Figure 6 Removing the Front Frame Knobs

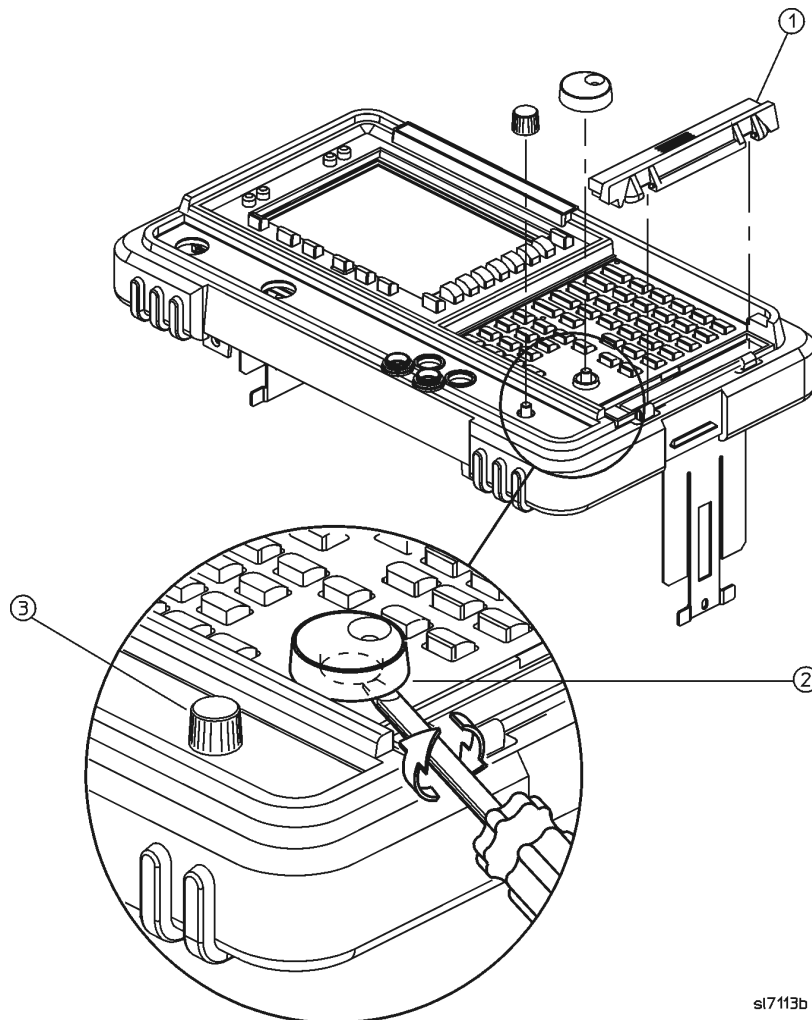

sl71f3b

4. Refer to [Figure 7](#). Disconnect the two 2-wire backlight cables (1) from the front panel interface inverter board.
5. Disconnect W3 ribbon cable (2) from the front panel interface board.

Figure 7 Disconnecting the Front Frame Wiring Connections

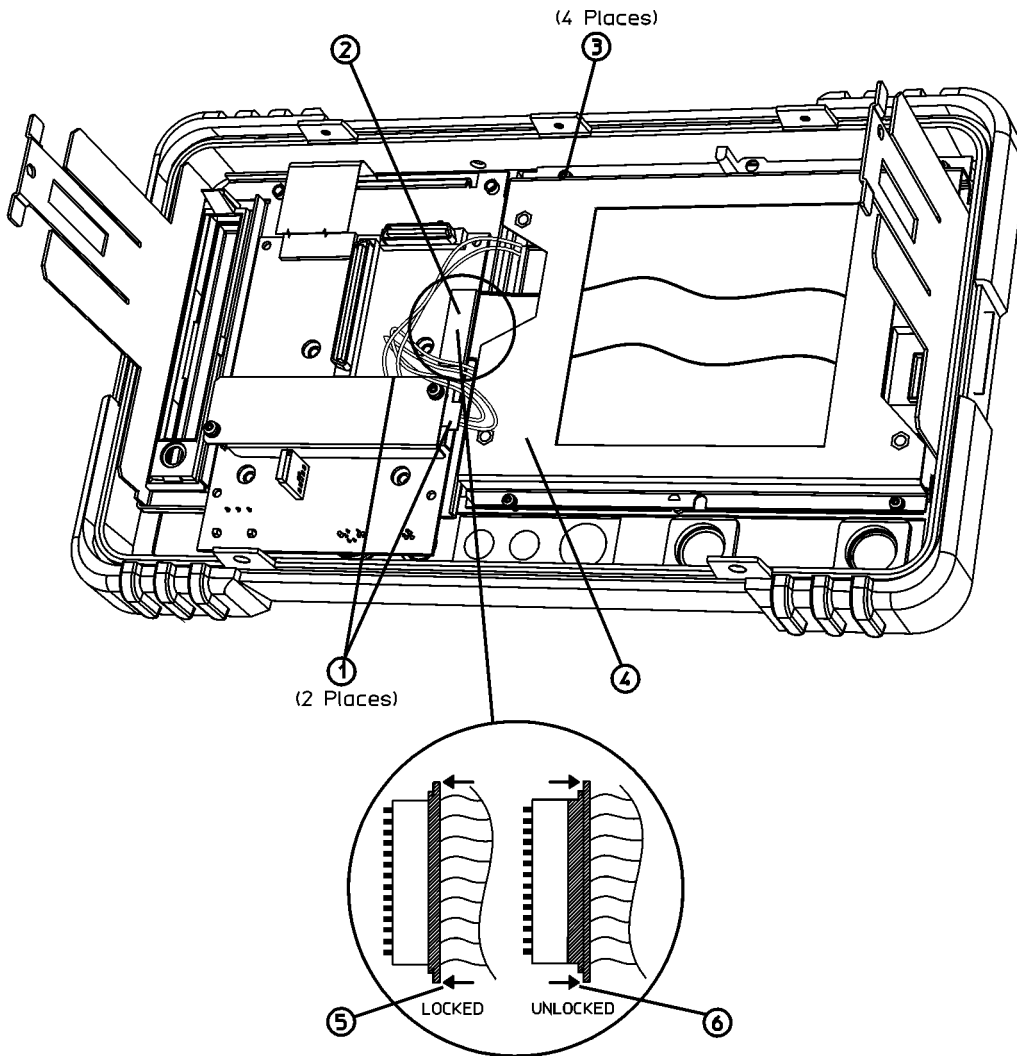

st748b

CAUTION The W3 display ribbon cable connector (2) is delicate. With a small screwdriver or similar tool, gently push the lock tabs out from the back of the connector. Excessive force on the locking tab can break the retaining clips, and if broken, board replacement will be necessary.

6. Refer to [Figure 8](#). Remove the four screws (10) that secure the A1A1 front panel interface board (11) to the front frame.
7. Remove the front panel interface board from the front frame assembly.

Removal

NOTE There is a water-seal gasket placed around the volume control shaft that will need to be repositioned during the replacement procedure.

Figure 8 Front Frame Assembly Parts

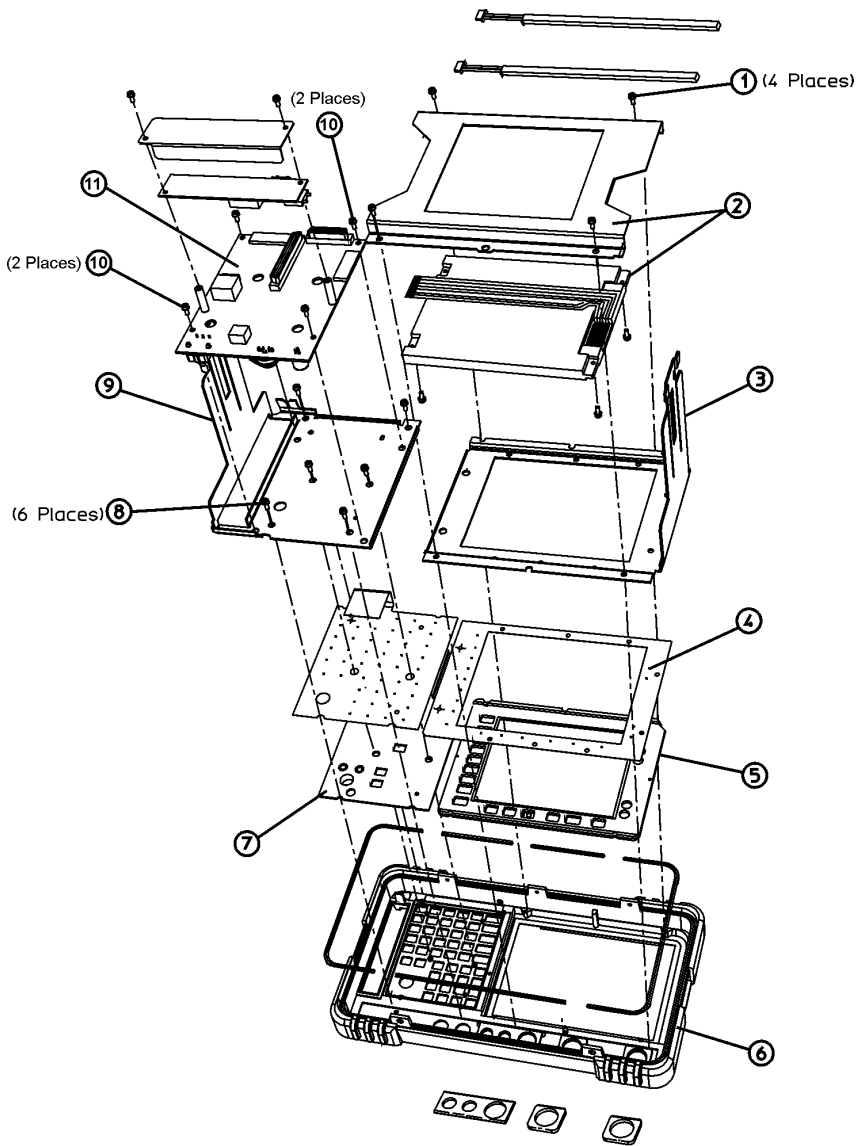

jl73a

Attach Connector Label and Connector Covers to Front Frame

1. Locate the appropriate connector label in the kit. The connector label has holes to accommodate the various front panel connectors and the volume control. The frequency range of the analyzer appears near the hole next to the INPUT connector. This kit contains two connector labels identifying different frequency ranges for analyzers with and without option UKB. Choose the connector label that is appropriate for the analyzer being retrofitted.
2. If the analyzer does not have a tracking generator, remove the hole plug for the RF OUT connector.
3. Remove the two connector covers from the front panel by pinching them from the sides and removing them (4) through the front of the front frame assembly.

Figure 9 Connector Covers

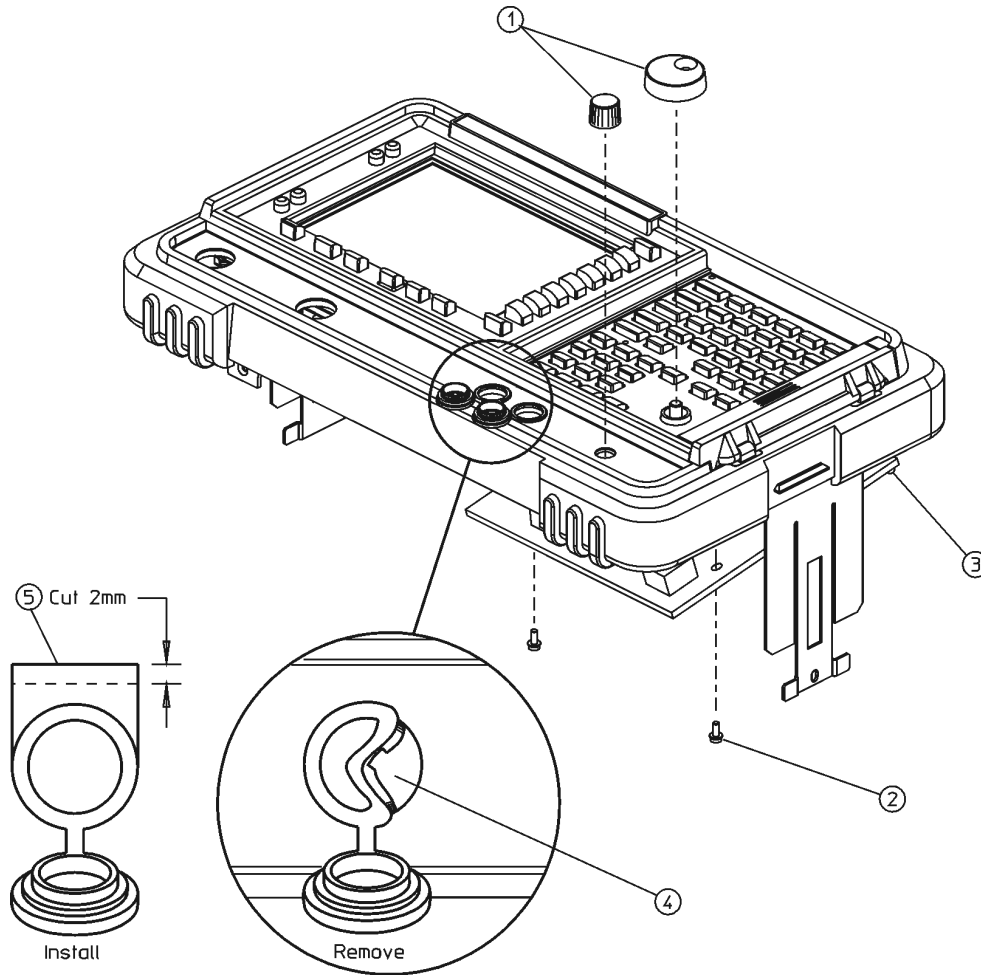

sl711b

Figure 10 **Connector Label Installation**

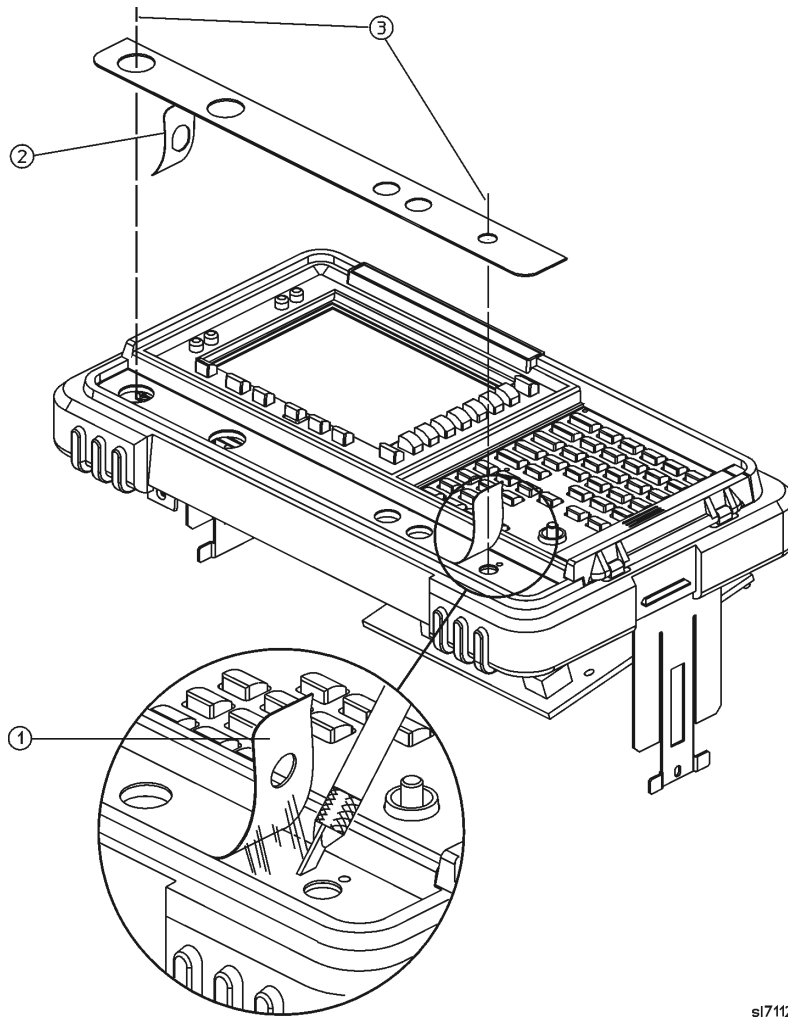

sl7112b

4. Peel off the old connector label loosening any residual adhesive with a sharp knife or razor blade as you go.
5. Before installing the new connector label, make sure the surface is free of any adhesive residue left from the old label. Failure to do so may result in an uneven (lumpy) appearance of the new label.
6. Peel the backing (2) off the new label, as shown in [Figure 10](#).
7. Align and install the label by placing a finger in the RF OUT and VOLUME holes (3). Observe the alignment of the INPUT and PROBE POWER holes.

Refer to [Figure 9](#).

TIP It may be helpful to trim off about 2 mm of the tabs (5) on the connector covers prior to reinstalling them. This will help in aligning the covers.

8. Reinstall the two connector covers from the front panel by pinching them from the sides and installing them through the front of the assembly.
9. Align the connector covers so they open downward.
10. Reinstall the hole plug that was removed if your analyzer does not have a tracking generator.

Add Cables and Connectors for External Mixing

Figure 11 Installing SMA to SMA Connectors

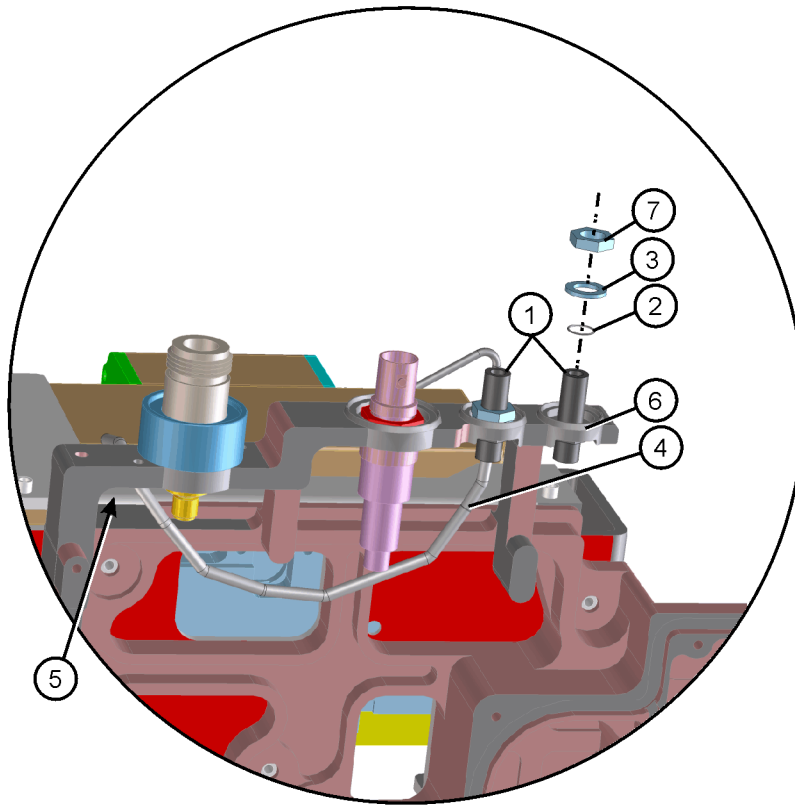

dt84a

1. Locate the SMA to SMA connectors, flat washer, and o-rings in the kit. Each SMA to SMA connector includes a hex nut. Remove this nut from the connector.
2. Refer to [Figure 11](#). Install the SMA to SMA connectors (1) from the backside of the “mid section” (6). Secure each connector with an o-ring (2), flat washer (3), and the nut (7) that was included with the connector as shown in the figure. Torque the nut to 21 inch-pounds.
3. Connect one end of the flexible coax cable, W39 (4) included in the kit to the back of the SMA to SMA connector nearest the BNC AMPTD REF OUT connector. Torque the connector to 10 inch-pounds.
4. Route the other end of W39 (4) through the hole (5) in the midsection as shown in [Figure 11](#).

Figure 12 Connecting the Semi-Rigid Coax Cable

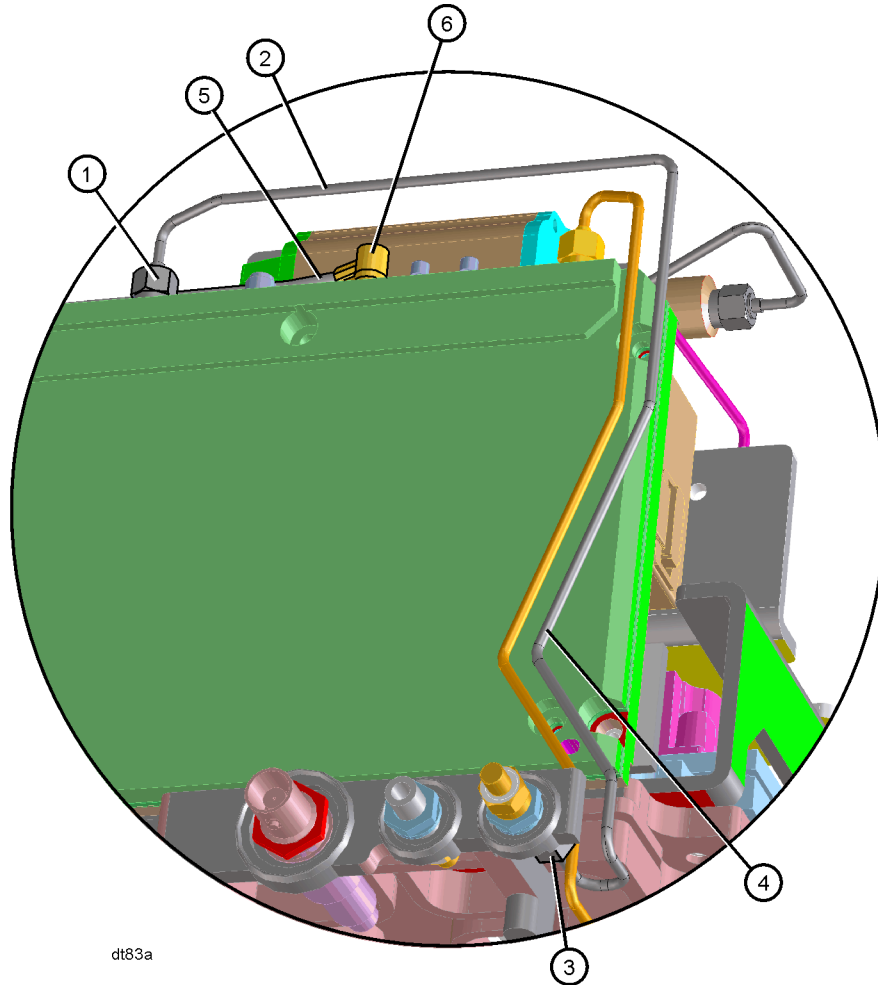

1. Refer to [Figure 12](#). Remove the 50 Ohm termination connected to A8A4J4 (1). The termination will later be connected to the 1st LO OUTPUT connector on the front panel.
2. Connect the semi-rigid coax cable, W38 (2) between A8A4J4 (1) and the remaining SMA to SMA connector (3) on the midsection. Ensure that W38 stays parallel to W23 (4). Torque the connections to 10 inch-pounds.
3. Connect the free end of W39 (5) to A8A4J6 (6).

Replace A1A1 Front Panel Interface Board

1. Refer to [Figure 8](#). Place the front panel interface board (11) in the correct position in the front frame assembly. Make sure the water seal is in place around the volume control shaft.
2. Replace the four screws that secure the board to the front frame. Tighten them to 9 inch-pounds.
3. Refer to [Figure 7](#). Connect the W3 display ribbon cable (2) to the front panel interface board.

TIP

An easy way to insert this delicate cable into the connector is to place your finger on the cable, in the center of the LCD display, and gently slide the cable toward the connector until they align. Then, providing guidance with the other hand as necessary, slide the cable until the end slips into the connector.

Ensure the cable end is seated completely and is aligned straight within the connector body.

Continue to hold the cable in place with your finger, and with the other hand gently press the locking tabs (5) into place.

If you experience display problems, check this connection.

4. Reconnect the two 2-wire backlight cables (1) to the inverter board, making sure that the cables are dressed away from the openings for the control knobs.
5. Press the volume and RPG knobs onto their control shafts.

Replace Front Frame Assembly

1. Align the A1 front frame subpanel rails with the chassis as shown in [Figure 13](#).

Figure 13 Front Frame Assembly Replacement

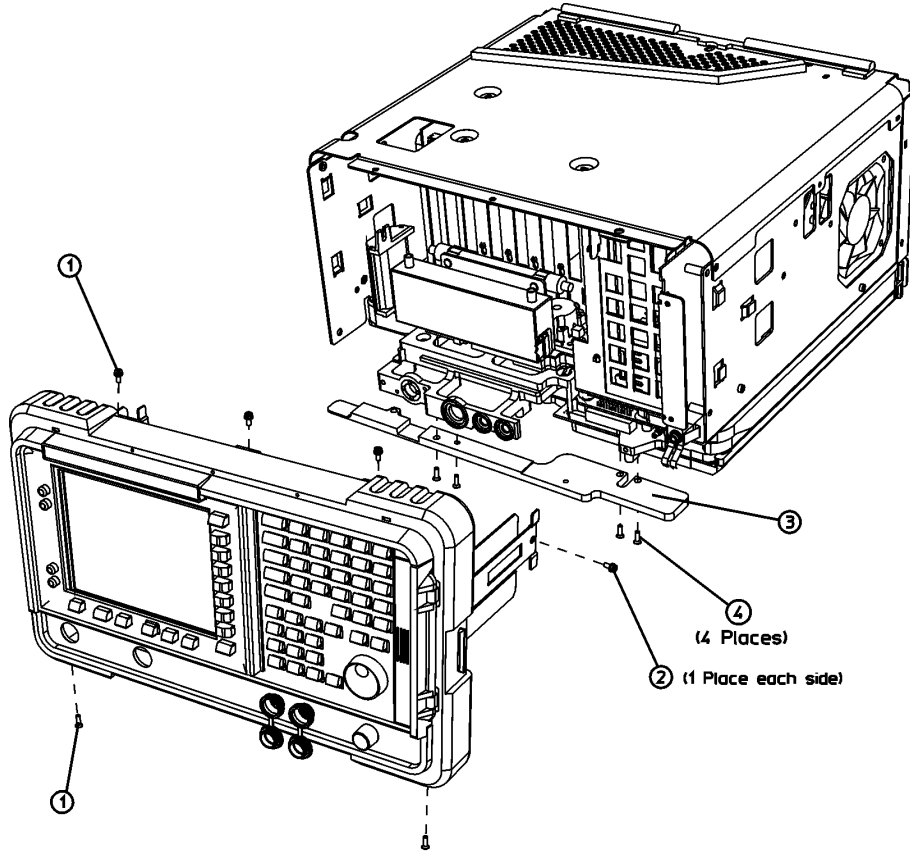

sl7118b

2. Refer to [Figure 14](#). Connect the ribbon cable (1) to the front frame assembly. If Option B7B is installed, there will be two ribbon cables to connect.

Figure 14 **Front Frame Ribbon Cable**

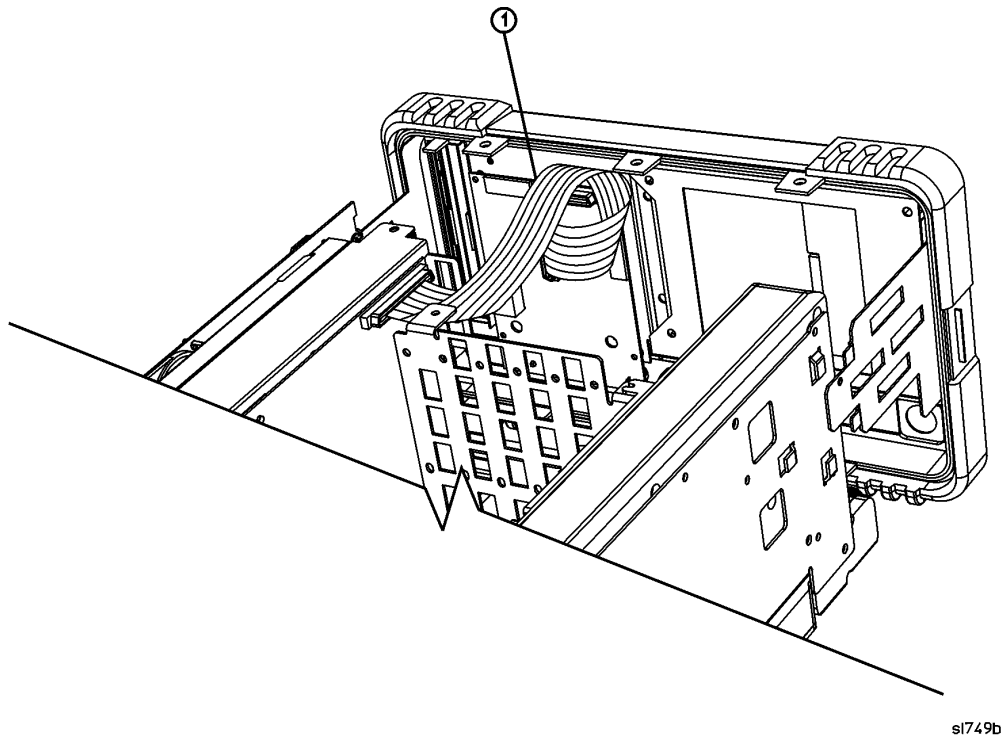

3. Carefully slide the front frame toward the chassis, assuring the ribbon cable(s) are not pinched between assemblies, and the RF input connector lines up correctly with the opening in the front frame.
4. Refer to [Figure 13](#). Replace the screws that secure the front frame to the chassis (2) and to the RF assembly (1). Tighten them to 9 inch-pounds.
5. Connect the 50 ohm termination removed earlier to the 1st LO OUTPUT connector.

Replace Chassis Cover

Figure 15 Chassis Cover Replacement

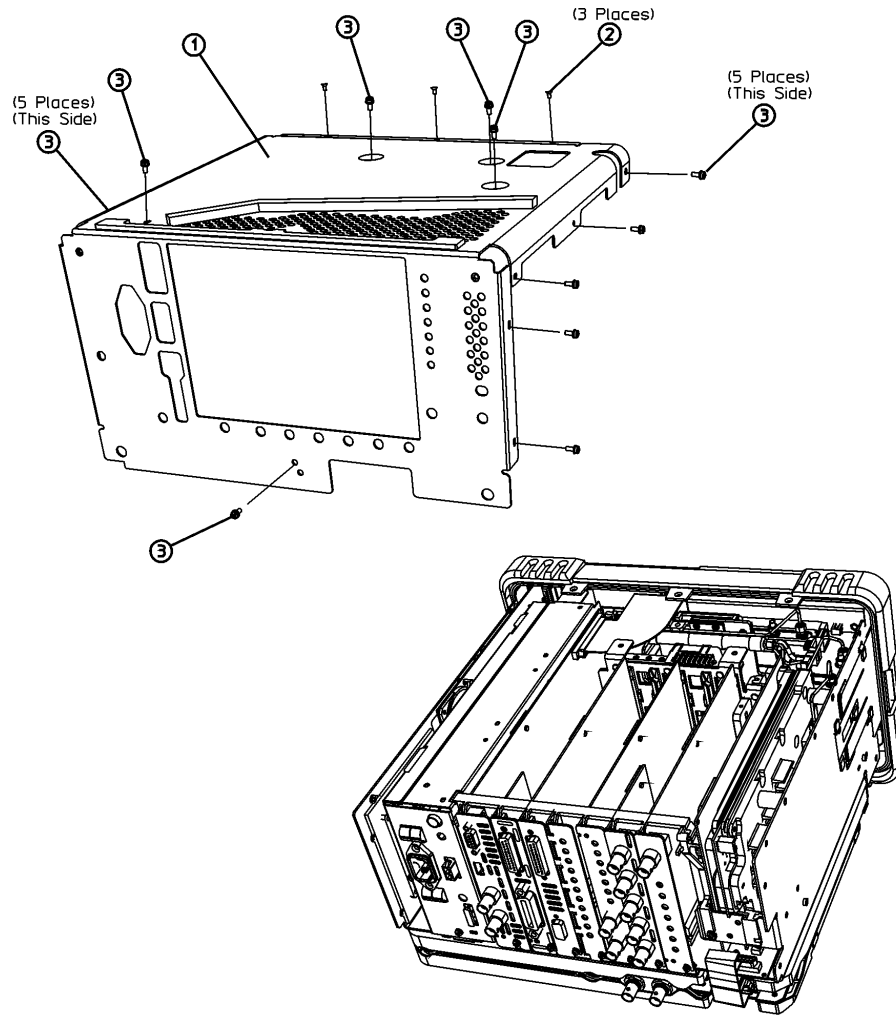

sl746b

1. Carefully position the chassis cover (1) on the instrument as shown in [Figure 15](#), then lower onto the instrument.
2. Replace the screws (3) as indicated on the instructions on the chassis cover. Tighten the screws to 9 inch-pounds.

Replace Dress Cover

1. Refer to [Figure 16](#). Carefully place the spectrum analyzer on the work surface with the front frame (3) facing down.
2. Replace the dress cover, matching the grill (8) on the bottom of the dress cover to the bottom of the analyzer.
3. Fit the leading edge of the dress cover completely into the slot (9) on the back of the front frame assembly.
4. Replace the rear frame assembly (6) using the four screws (5) to fasten the rear frame to the analyzer.

Figure 16 Dress Cover, Rear Frame Replacement

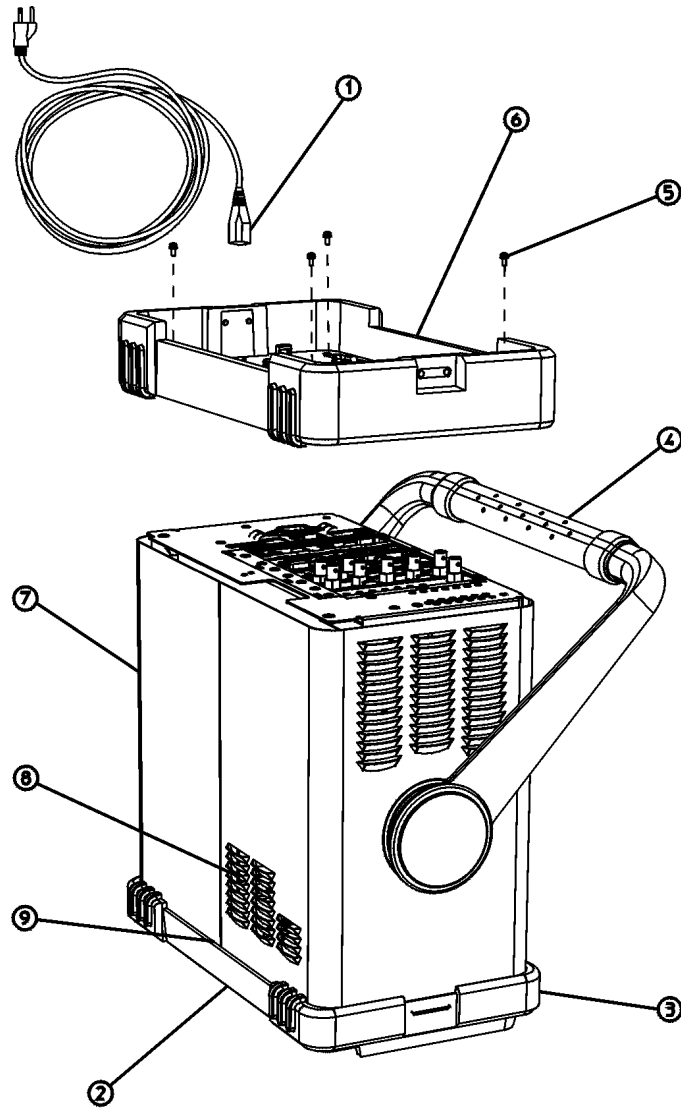

sl745b

Firmware Revision Verification

1. Turn on the analyzer and wait for the power-on alignments to complete. Check that there are no error messages displayed.
2. Press **System, More, Show System**. Make a note of the firmware revision and see if Option B72, Expansion Memory, is listed on the display.
3. If the firmware revision is A.04.00 or later, the firmware does not need to be upgraded and you can skip steps 4 through 6.
4. If your firmware revision is prior to A.04.00, you must upgrade your analyzer firmware before the license key can be activated.
5. If Option B72, Expansion Memory is installed, you should upgrade the instrument firmware to the latest version using one of the following methods:
 - Download the instrument firmware via the world-wide web at http://www.agilent.com/find/esa_firmware. This entire process of upgrading firmware will take approximately 45 minutes.
Note: If you are upgrading an EMC analyzer, look for the link stating “*EMC Firmware*” at this website.
 - Receive the latest firmware upgrade disk set by ordering upgrade Option UE2.
Note: Special instructions in the Agilent ordering configurator should have made you aware of Option UE2 in case access to the internet wasn't available.
6. If Option B72, Expansion Memory is not installed, you should upgrade the instrument firmware to version A.07.05. This is the latest version for instruments that do not have Option B72 installed.
 - Download the instrument firmware via the world-wide web at http://www.agilent.com/find/esa_firmware. Look for the link stating “*ESA Firmware Version A.07.05*”. This entire process of upgrading firmware will take approximately 45 minutes.
 - Order upgrade Option B72, which includes the expansion memory and the latest ESA firmware upgrade disk set.

Activate the Option AYZ License Key

The license key supplied in this kit allows you to activate External Mixing (Option AYZ).

1. Press **System, More, More, Licensing, Option**. When you press **Option**, the alpha editor will be activated. For instructions on using the alpha editor, refer to the *Agilent Technologies ESA Spectrum Analyzers User's Guide*.
2. Use the alpha editor to enter the three-character designation for the option, in this case, "AYZ", that you want to activate.
3. Press **Enter** when done.
4. Press **License Key**. When you press **License Key** the alpha editor will be activated.
5. Use the alpha editor and the numeric keypad to enter the 12-character license key number (for example: D7C374DABD5B) for the option that you want to activate.
6. Press **Enter** when done.
7. Press **Activate** to turn on the option.
8. If the option and license key entries were correct, a message stating "Option Activated" will appear on the analyzer display.

Adjustments and Performance Verification

1. Verify that Option AYZ was activated by pressing **System, More, Show System**. Verify that there is an entry which reads, "AYZ: External Mixing".
2. Perform the IF INPUT Correction and LO Power adjustment, located in the Performance Verification and Adjustment Software.
3. Perform the following performance verification tests, located in the *Agilent Technologies ESA Spectrum Analyzers Calibration Guide*:
 - Frequency Response
 - Displayed Average Noise Level
 - Residual Responses
 - 1st LO OUTPUT Power Accuracy
 - IF INPUT Accuracy
 - System Related Sidebands
4. If the Frequency Response test fails, perform the LO power adjustment followed by the Frequency Response adjustment.
5. If you have problems performing either of these tests, contact the nearest Agilent Technologies sales and service office listed in the troubleshooting chapter of the *Agilent Technologies ESA Spectrum Analyzers User's Guide*.